

HELLER Machining centres

Technical data MCH

Model		MCH 300	MCH 350	MCH 400	MCH 450	MCH 460		
Working range	Longitudinal stroke (X-axis)	mm	1,000	1,250	1,400	1,600	2,000	
	Vertical stroke (Y-axis)	mm	1,000	1,000		1,200	1,400	
	Transverse stroke (Z-axis)	mm	1,000	1,000	1,250			
Feed thrusts	X- and Y-axis with duty cycle = 40%	N	15,000					
	Z-axis with duty cycle = 40%	N	17,500					
Speeds	In X-, Y- and Z-axis / rapid traverse	mm/min.	50,000		40,000			
	Acceleration	m/s ²	4.0					
Dynamic package*	In X-, Y- and Z-axis / rapid traverse	mm/min.	60,000		–			
	Acceleration	m/s ²	5.0		–			
Spindle unit	Spindle diameter in front bearing	mm	100					
	Spindle taper	SK/HSK/BT	50/A100/50					
Gear unit	Drive power/torque (max.) with duty cycle = 40%	kW/Nm	43/822					
	Speed range	rpm	45–6,000					
Hollow shaft unit*	Drive power/torque (max.) with duty cycle = 40%	kW/Nm	72/460					
	Speed range	rpm	45–12,500					
Enhanced gear unit*	Drive power/torque (max.) with duty cycle = 40%	kW/Nm	60/1,145					
	Speed range	rpm	45–6,000					
Tool magazine	Max. tool diameter (all places occupied)	mm	112					
	Max. permissible tool weight	daN	25/35*					
	Max. permissible moment of tool weight at the gripper	Ncm	2,200/5,000*					
Dynamic package*	Chip-to-chip time to VDI	to 12/25 daN	s	4.4/5.4	4.7/5.7	5.4/6.4	5.7/6.7	6.1/7.1
		to 12/25 daN	s	4.2/5.2	4.5/5.5	–		
Chain-type magazine	Tool pockets	number	50/100*					
	Max. tool length (from spindle nose)	mm	600					
	Max. tool diameter (free places required)	mm	228/280*					
Rack-type magazine*	Tool pockets	number	106/234/405/590					
	Max. tool length (from spindle nose)	mm	600	600/1,000*				
	Max. tool diameter (free places required)	mm	280	280/320*				
Rotary table	Max. admissible clamping load (center)	daN	1,250		2,500/4,000*			
	Rotary indexing table	Indexing division	degrees	360 x 1°				
Indexing accuracy		arc s	6					
Indexing times for 45°/180°		s	3.8/5.1		2.9/4.6			
Rotary feed table*	Division	degrees	360,000 x 0,001°					
	Positioning accuracy	arc s	10					
	Positioning times for 45°/180°	s	1.1/3.2		1.6/3.7			
Pallet changer	Pallet design	mm	800 x 800		800 x 1,000			
	Pallet changing accuracy in X-, Y- and Z-axis	mm	0.02					
	Pallet changing time	s	17		27/40*			
Measuring system	Direct linear scales in X-, Y- and Z-axis with highest resolution							
	Positioning tolerance Tp (to VDI/DGQ 3441)	mm	0.009		0.01			
Coolant unit	Coolant tank, basic version, capacity	approx. Liter	1,500		2,500			
	Coolant pump, delivery volume	at 3 bar	Liter/min.	170+40		230+70		
		at 50 bar	Liter/min.	28				
		at 40 bar*	Liter/min.	38				
		at 70 bar*	Liter/min.	22				
Installation data	Machine weight	approx. daN	21,000	22,000	26,000	27,000	28,000	
	Total power requirement, basic version	approx. kVA	85					
	Mains connection		400 V/50 Hz					
	Compressed air	bars	6					
Machine control	Siemens SINUMERIK 840D pl		■					
	Fanuc 160i		■					

Remark: All data relates to Siemens control Siemens SINUMERIK 840D pl

*Option

Technical data MCH

Dimensions MCH 300 / 350

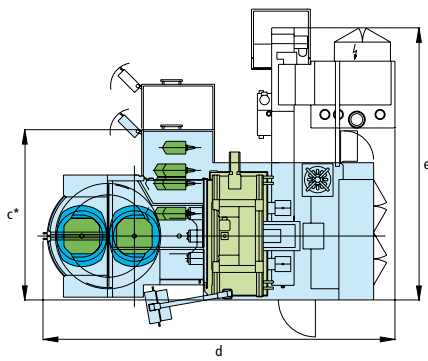
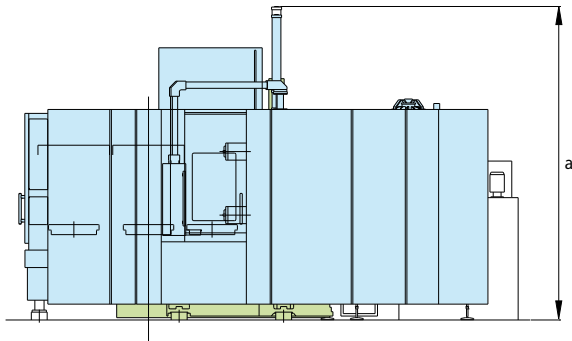

Model	MCH 300	MCH 350
a	4,400	4,400
b	3,500	3,500
c*	3,500	3,600
d	7,100	7,100
e	5,200	5,200

*Chain-type magazine with 50 pockets

Dimensions MCH 400 / 450 / 460

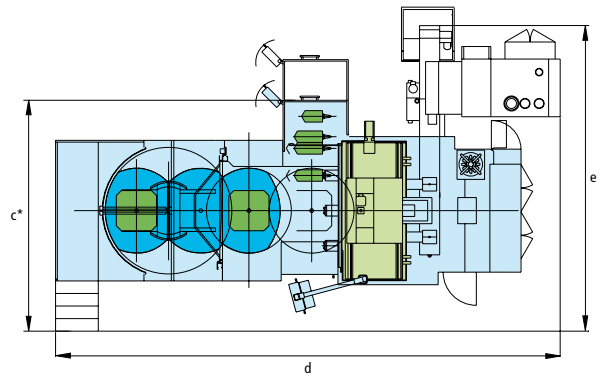
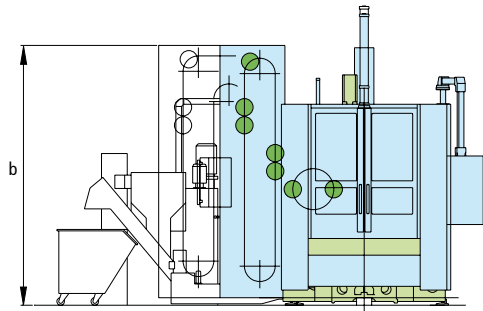

Model	MCH 400	MCH 450	MCH 460
a	4,400	4,800	5,200
b	3,500	3,500	3,500
c*	4,700	4,800	5,000
d	10,500	10,100	10,300
e	6,200	6,200	6,200

*Chain-type magazine with 50 pockets

Technical data MCH

Interference diameter MCH 300 / 350

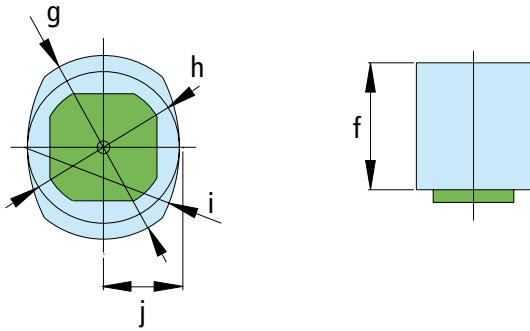

Model	MCH 300	MCH 350
f	1,200	1,200
g	ø 1,290	ø 1,540
h	ø 1,250	ø 1,250
i	R 1,285	R 1,285
j	660	660

Interference diameter MCH 400 / 450 / 460

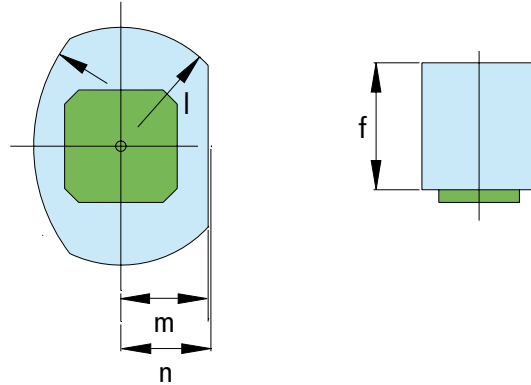

Model	MCH 400	MCH 450	MCH 460
f	1,450	1,450	1,450
k	R 1,260	R 1,260	R 1,500
l	ø 1,690	ø 1,890	ø 2,290
m	620	620	620
n	640	640	640

Gear unit

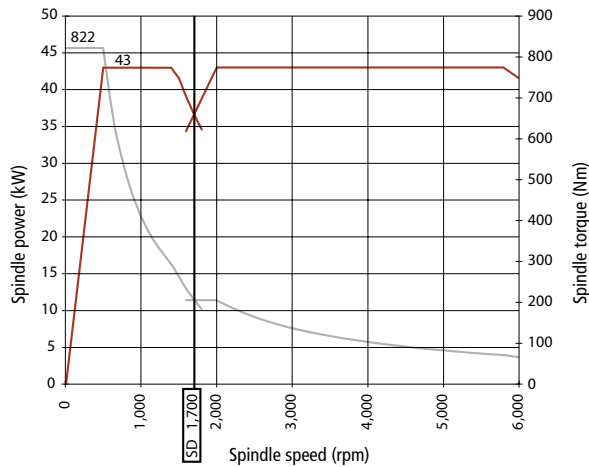

— Power S6/40% i=1/i=4
 — Torque S6/40% i=1/i=4
 SD ... Switching speed rpm

Hollow-shaft unit

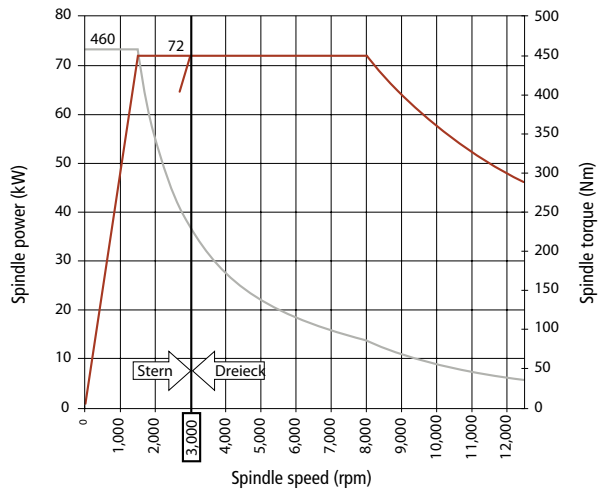

— Power star/delta
 — Torque star/delta
 SD ... Switching speed rpm

Enhanced gear unit

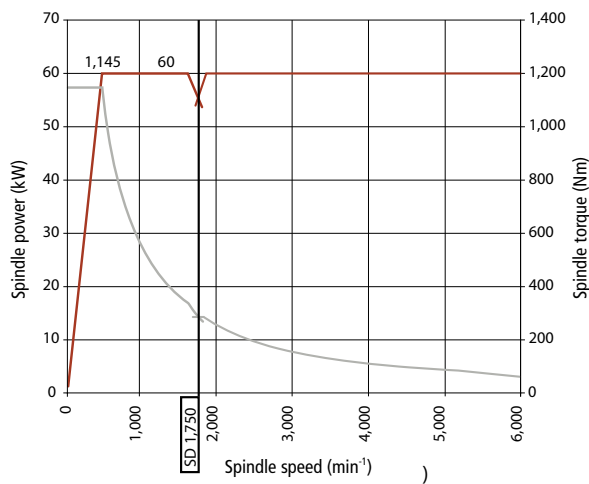

— Power S6/40% i=1/i=4
 — Torque S6/40% i=1/i=4
 SD ... Switching speed rpm